

THERE'S WORK TO DO.

THE OX TOP DRIVE SERIES IS A BEAST.

**THERE'S
WORK
TO DO.**



Box 8 • 2002 Kingbird Ave. • George, IA 51237 USA
1-888-SUDENGA (783-3642) • 1-712-475-3301
Fax: 1-712-475-3320 • sales@sudenga.com • www.sudenga.com



The TD-450 (Top Drive Series) Ox portable auger features multiple drive options, including electric, PTO, hydraulic, and gas engine. Available in tube diameters of 6", 8", 10", 12" and NEW 14". Standard cage intake, optional 17° hopper. Let it load and unload your grain bins. Let it fill or take away from your dryers. Just let it work. Available in painted or galvanized finishes.

TD-450

Portable Augers



SPECIFICATIONS

	6" AUGERS	8" AUGERS	10" AUGERS	12" AUGERS	14" AUGERS
Tube Ga. - Finish	14 ga. - paint or galv.	14 ga. - paint or galv.	12 ga. - paint or galv.	12 ga. - paint	12 ga. - paint
Flight Ga. ¹ - Tube ID	10 ga. - 1"	3/16" - 1 1/2"	3/16" - 2 1/2"	1/4" - 2 7/8"	5/16" - 2 7/8"
Driveshaft Dia.	1"	1"	1 1/4"	1 1/4"	1 1/4"
Head Chain	Single #50 (all lengths)	Single #60 (all lengths)	Single #80 (all lengths)	Single #80 (31'-41') Double #80 (51'-71')	Double #80 (31'-41') Belt drive #80 (51'-86')
Gearbox ² Shaft Diameter	1 1/4"	1 1/4"	1 1/4"	1 1/4" (31'-41') 1 1/2" (51'-71')	1 1/2"
Transport Arms	1 7/8" round tube (26'-36') 2" x 4" box upper & 2" x 3" box lower (41'-71')	1 7/8" round tube (26'-36') 2" x 4" box upper & 2" x 3" box lower (41'-71')	1 7/8" round tube (26'-36') 2" x 4" box upper & 2" x 3" box lower (41'-71')	2" x 4" box upper & 2" x 3" box lower all lengths	2" x 4" box upper & 2" x 3" box lower all lengths
Transport Width	7' 8" (26'-41') 10' (51'-71')	7' 8" (26'-41') 10' (51'-71')	7' 8" (26'-41') 10' (51'-71')	7' 8" (31'-41') 10' (51'-71')	7' 8" (31'-41')

¹Intakes on all augers are double flighted. ²Gearbox is a right angle type, with miter cut gears and 1:1 ratio.



CAGE INTAKE



PTO DRIVE



OPTIONAL HOPPER

RECOMMENDED HORSEPOWER

	26'	31'	36'	41'	51'	56'	61'	66'	71'
6" Electric†	3 - 3	3 - 3	5 - 3	5 - 3	7.5 - 3	7.5 - 5	7.5 - 5	—	—
6" Gas	13	13	13	13	—	—	—	—	—
6" Hydraulic*	H	H	H	H	H	H	H	—	—
6" PTO**	7	9	10	11	14	16	18	—	—
8" Electric†	5 - 3	5 - 3	7.5 - 5	7.5 - 5	10 - 5	10 - 7.5	10 - 7.5	15 - 7.5	15 - 7.5
8" Gas	20	20	20	20	—	—	—	—	—
8" Hydraulic*	H	H	H	H	2,000	2,000	2,000	2,000	2,000
8" PTO**	11	13	16	18	22	24	26	28	30
10" Electric†	7.5 - 7.5	7.5 - 7.5	10 - 7.5	10 - 7.5	15 - 7.5	15 - 10	15 - 10	20 - 10	20 - 10
10" Gas	20	20	20	—	—	—	—	—	—
10" Hydraulic*	2,000	2,000	2,000	2,000	2,000	2,000	—	—	—
10" PTO**	16	19	22	25	31	34	37	40	43
12" Electric†	15	15	15	20	20	—	—	—	—
12" Hydraulic*	2,000	2,000	2,000	—	—	—	—	—	—
12" PTO**	23	28	33	38	46	50	55	59	64
14" PTO**	—	39	45	51	64	70	76	83	89

† First HP is for dry corn. Second HP is for slow down kit.

* Calculated assuming tractor hydraulics put out 14 GPM (determines auger RPM) and maximum of 1800 PSI for H series motors.

Also assuming 14 GPM (determines auger RPM) for the 2000 series but with a maximum of 3000 PSI.

** Minimum PTO HP

HOPPER DIMENSIONS 17" OR HINGED

Tube Dia.	Length	Width	Depth
8"	28"	27"	10"
10"	32 1/2"	26 1/2"	11 3/4"
12"	32 1/2"	26 1/2"	13"
14"	38 1/2"	32"	15"

STANDARD FEATURES

- 6", 8", 10", 12" and 14" diameter tubes
- Painted finish available in all sizes
- Galvanized tube finish available on sizes 6", 8" and 10".
- A-frame transport with manual winch
- Hydraulic winch; 12" & 14" augers
- PTO, electric, gas, and hydraulic drives

OPTIONS

- 17" or hinged hopper with removable hitch
- Hydraulic winch for 8" and 10" auger
- Swivel transport
- Wheeled jack
- Plastic hopper



CAPACITIES

6" Augers	1,200-1,400 BPH
8" Augers	2,100-2,400 BPH
10" Augers	3,200-3,600 BPH
12" Augers	5,000-5,400 BPH
14" Augers	10,000-11,000 BPH

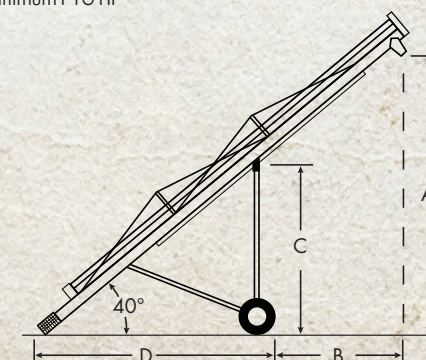

REACH & ELEVATION

	AUGER LENGTH								
	26'	31'	36'	41'	51'	56'	61'	66'	71'
A - Elevation	16'	19'	23'	26'	31'	35'	38'	41'	44'
B - Reach	7'	10'	11'	14'	15'	18'	20'	21'	24'
C - Height	12'	13'	15'	16'	20'	21'	23'	25'	26'
D - Distance	14'	15'	17'	18'	25'	26'	28'	30'	31'