

THIS IS THE OX HI-EFFICIENCY SERIES.

IT'S BUSY RIGHT NOW.

THERE'S WORK TO DO.



Box 8 • 2002 Kingbird Ave. • George, IA 51237 USA
1-888-SUDENGA (783-3642) • 1-712-475-3301
Fax: 1-712-475-3320 • sales@sudenga.com • www.sudenga.com



The Hi-Efficiency portable auger features a versatile hydraulic scissor lift, bottom drive PTO, and gimbal mount hinged hopper. Up to 82' long, and capacities up to 7,000 BPH. If you're looking to goof around, keep looking. Available in painted or galvanized finishes.

HI-EFFICIENCY Portable Augers

SPECIFICATIONS

| | 8" AUGERS | 10" AUGERS | 12" AUGERS |
|--------------|--|-------------------------|---------------|
| Tube Lengths | 57', 61', 65', 71' | 61', 66', 71', 76', 82' | 61', 72', 82' |
| Tube Gauge | 14 | 12 | 12 |
| Tube Finish | Painted or galvanized | | Painted |
| Flighting | 3/16" | | 1/4" |
| Driveline | Direct constant velocity joint on PTO-to-flighting connection; double bearings; shear pin protection | | |
| Transport | Hydraulic scissor lift; 4-bolt rims (8" augers) or 6-bolt rims (10"/12" augers); roller bearings for road transport. Transport widths: 10' (8" augers) and 10½' (10"/12" augers). | | |
| Swing Hopper | Mechanically driven by roller chain and double gearbox from auger flight; gimbals mount is easy to position; UHMW sealed hopper joint keeps weather out and grain in (PAT NO. 5,788,055); 10" and 12" hoppers are hinged at the hopper to incline joint. CV joint is standard on 10" and 12". Hopper intake flighting is 5/16" thick on all models. | | |



TWIN SCREW HOPPER

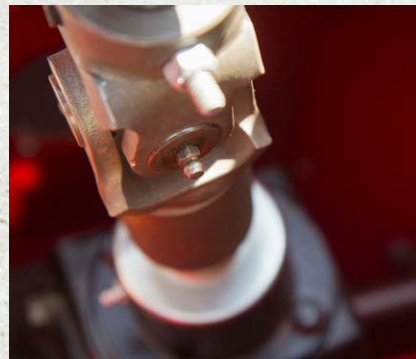

GREASE FITTINGS



GREASE FITTING ACCESS



COUNTER-BALANCED HITCH

STANDARD FEATURES

- 8", 10" and 12" diameter tubes
- 8" and 10" galvanized or painted finish
- 12" painted finish
- Hydraulic cylinder scissor lift and heavy duty top and side cable trussing for rigid performance.

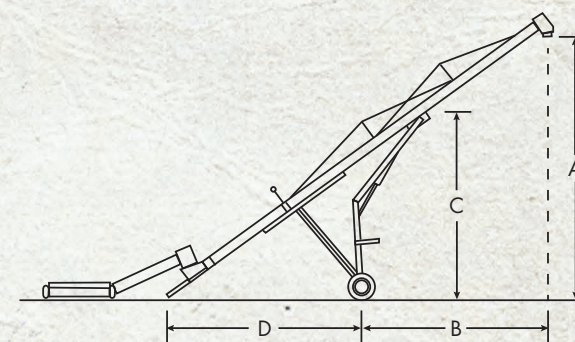

REACH & ELEVATION

| Augers at 40° | 57' | 61' | 65' | 71' | 76' | 82' |
|---------------|-----|-----|-----|-----|-----|-----|
| A - Elevation | 39' | 42' | 46' | 49' | 52' | 56' |
| B - Reach | 21' | 25' | 25' | 29' | 33' | 33' |
| C - Height | 20' | 20' | 25' | 25' | 25' | 28' |
| D - Distance | 21' | 21' | 25' | 25' | 25' | 28' |

| Augers at 30° | 57' | 61' | 65' | 71' | 76' | 82' |
|---------------|-----|-----|-----|-----|-----|-----|
| A - Elevation | 30' | 33' | 36' | 39' | 42' | 44' |
| B - Reach | 23' | 28' | 28' | 33' | 37' | 37' |
| C - Height | 15' | 15' | 15' | 15' | 19' | 21' |
| D - Distance | 23' | 23' | 25' | 23' | 29' | 34' |

ACCESSORIES

| | 8" AUGERS | 10" AUGERS | 12" AUGERS |
|--|-----------|------------|------------|
| 1/4" Ga. Flighting | Optional | Optional | Standard |
| Discharge Spout | Optional | Optional | — |
| Overflow Spout | Optional | Optional | Standard |
| 4' & 6' Bucket Spout | Optional | Optional | — |
| 3' Metaflex Hose | Optional | Optional | — |
| 4' Screen - Hopper Incline Tube | Optional | Optional | — |
| Low Profile Twin Screw Hopper | — | Optional | Standard |
| Power Rotation for Hopper ¹ | — | Optional | Optional |
| Side Drive Kit ² | Optional | Optional | Optional |

¹Hydraulic or electric positioning for hopper.

²Puts tractor at 90° to auger for more hopper swing.

AUGER CAPACITIES

| | |
|--------------|-----------|
| 8" Diameter | 3,200 BPH |
| 10" Diameter | 5,000 BPH |
| 12" Diameter | 7,000 BPH |