

**THERE'S WORK TO DO.**

**THE OX TOP DRIVE SERIES IS A BEAST.**

THERE'S  
WORK  
TO DO.



Box 8 • 2002 Kingbird Ave. • George, IA 51237 USA  
1-888-SUDENGA (783-3642) • 1-712-475-3301  
Fax: 1-712-475-3320 • sales@sudenga.com • www.sudenga.com



The TD-450A (Top Drive Series) Ox portable auger features multiple drive options, including electric, PTO, hydraulic, and underslung gas engine. Available in tube diameters of 6", 8", 10", 12" and NEW 14". Standard cage intake, optional 17° hopper. Let it load and unload your grain bins. Let it fill or take away from your dryers. Just let it work. Available in painted or galvanized finishes.

# TD-450

## Portable Augers



### SPECIFICATIONS

	6" AUGERS	8" AUGERS	10" AUGERS	12" AUGERS	14" AUGERS
Tube Ga. - Finish	14 ga. - paint or galv.	14 ga. - paint or galv.	12 ga. - paint or galv.	12 ga. - paint	12 ga. - paint
Flight Ga. <sup>1</sup> - Tube ID	10 ga. - 1"	3/16" - 1½"	3/16" - 2½"	1/4" - 2-7/8"	5/16" - 2-7/8"
Driveshaft Dia.	1"	1"	1¼"	1¼"	1¼"
Head Chain	single #50 all lengths	single #60 all lengths	single #80 all lengths	single #80 (31'-41') double #80 (51'-71')	double #80 all lengths
Gearbox <sup>2</sup> Shaft Diameter	1¼"	1¼"	1¼"	1¼" (31'-41') 1½" (51'-71')	1½"
Transport Arms	1-7/8" round tube (26'-36') 2" x 4" box upper & 2" x 3" box lower (41'-71')	1-7/8" round tube (26'-36') 2" x 4" box upper & 2" x 3" box lower (41'-71')	1-7/8" round tube (26'-36') 2" x 4" box upper & 2" x 3" box lower (41'-71')	2" x 4" box upper & 2" x 3" box lower all lengths	2" x 4" box upper & 2" x 3" box lower all lengths
Transport Width	7'-8" (26'-41') 10' (51'-71')	7'-8" (26'-41') 10' (51'-71')	7'-8" (26'-41') 10' (51'-71')	7'-8" (31'-41') 10' (51'-71')	7'-8" (31'-41')

<sup>1</sup>Intakes on all augers are double flighted. <sup>2</sup>Gearbox is a right angle type, with miter cut gears and 1:1 ratio.



CAGE INTAKE



PTO DRIVE



OPTIONAL HOPPER

### RECOMMENDED HORSEPOWER

	26'	31'	36'	41'	51'	56'	61'	66'	71'
6" Electric†	5-3	5-3	7.5-5	7.5-5	7.5-5	10-5	10-5	--	--
6" Gas	13	13	13	13	--	--	--	--	--
6" Hydraulic*	H	H	H	H	H	H	H	--	--
8" Electric†	7.5-5	7.5-5	10-7.5	10-7.5	15-7.5	15-10	15-10	20-10	20-10
8" Gas	20	20	20	20	--	--	--	--	--
8" Hydraulic*	H	H	H	H	2000	2000	2000	2000	2000
8" PTO	13	15.5	18	20.5	25.5	28	30.5	33	35.5
10" Electric†	10-7.5	15-7.5	15-10	15-10	20-15	20-15	25-15	25-15	25-15
10" Gas	20	20	20	--	--	--	--	--	--
10" Hydraulic*	2000	2000	2000	2000	2000	2000	--	--	--
10" PTO	19.5	23.25	27	30.75	38.25	42	45.75	49.5	53.25
12" Electric†	--	20	20	25	25	--	--	--	--
12" Hydraulic*	--	2000	2000	--	--	--	--	--	--
12" PTO	26	31	36	41	51	56	61	66	71
14" PTO	33.8	40.3	46.8	53.3	66.3	72.8	79.3	85.8	92.8

\* 1400 PSI is maximum required for "H" Series motors. 2700 PSI is maximum required for 2000 Series motors.F

† First HP is for dry corn. Second HP is for Slow Down Kit.

### HOPPER DIMENSIONS 17" OR HINGED

Tube Dia.	Length	Width	Depth
8"	28"	27"	10"
10"	32½"	26½"	11¾"
12"	32½"	26½"	13"
14"	38½"	32"	15"

## STANDARD FEATURES

- 6", 8", 10", 12" and 14" diameter tubes
- Painted finish available in all sizes
- Galvanized tube finish available on sizes 6", 8" and 10".
- A-frame transport with manual winch
- Hydraulic winch; 12" augers
- PTO, electric, gas, and hydraulic drives

### OPTIONS

- 17" or hinged hopper with removable hitch
- Swivel transport
- Wheeled jack
- Plastic hopper
- Hydraulic winch for 8" and 10" auger

### CAPACITIES

6" Augers	1,200-1,400 BPH
8" Augers	2,100-2,400 BPH
10" Augers	3,200-3,600 BPH
12" Augers	5,000-5,400 BPH
14" Augers	10,000-11,000 BPH

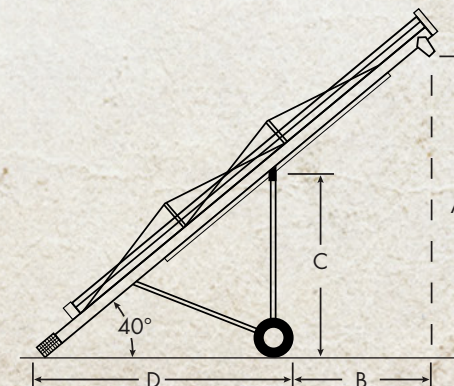

### REACH & ELEVATION

	AUGER LENGTH								
	26'	31'	36'	41'	51'	56'	61'	66'	71'
A - Elevation	16'	19'	23'	26'	31'	35'	38'	41'	44'
B - Reach	7'	10'	11'	14'	15'	18'	20'	21'	24'
C - Height	12'	13'	15'	16'	20'	21'	23'	25'	26'
D - Distance	14'	15'	17'	18'	25'	26'	28'	30'	31'